

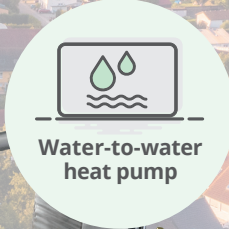

Heat pumps



Air-to-water heat pump



Water-to-water heat pump

Contents

Information about 2G

Facts	4
Advantages	5

General

Why a heat pump?	6
Accessories	8
Portfolio	9

Water-to-water heat pump

C-B-r R513A/R1234ze-VSD	10
C-B-sc R600a-VSD	12
C-S-r R717-VSD	14
C-G-r R717-VSD	16
D-SG-r R717-VSD	18

Air-to-water heat pump

M-sl-AEK R290	20
M-sl-PEK R290	22
M-sl3-AEK R290	24

Requirements

26

Service

Service products/services	38
Service products/services	40
TrainingCenter	42
MY2G	43

Facts about 2G

1995
company founded

Headquarters in **Heek**



> **1,000 employees**



Many years of **experience** in the heating market



Manufactured in **Germany**

COP of up to 9.5

R1234ze R513a R290
R600a R717
Use of **various refrigerants**



Air-to-water heat pump



Water-to-water heat pump

Hardware and software developers

17 Subsidiaries



Holistic system solution from 2G



Development in Germany according to VDE and DIN



Commissioning including testing of the COP

One solution, many advantages: The 2G heat pump

As a global technology leader and full-service partner, 2G offers its customers more than just a simple power generation system.



Comprehensive control concepts
incl. power take off (pump/mixer, data recording for heat source and heat sink)

Convenient system management
with MY2G (monthly reports, operational monitoring and much more)

Intelligent malfunction prediction
in connection with the 2G AI "I.R.I.S."

Higher-level control system
via master control (monitoring)

Integration of spot market optimization
Flex operation, re-dispatch, etc. via partners

Container solutions
in different sizes and solutions

Why a heat pump?

Use renewable environmental heat efficiently

Heat pump technology is one of the key technologies for the energy transition. In the residential sector in particular, heat pumps are already making an important contribution to decarbonising the energy supply by using the unlimited amount of ambient heat available for heating or hot water production.

However, the well-known and proven operating principle also shows its strengths on a larger scale. For example, large heat pumps in industry, trade, municipalities and large residential properties enable the highly efficient supply of renewable energy.

How does a heat pump work?

Regardless of the heat source and output, the operating principle of a heat pump is always the same: The heat is extracted from the source and fed into the heat pump circuit using a refrigerant. The compression of the refrigerant increases the pressure and temperature. If the heat is finally

dissipated to the heat sink, the temperature of the coolant is also reduced, making it liquid again. In the expansion valve, the coolant reaches its initial temperature again by lowering the pressure – and the circuit can start again.

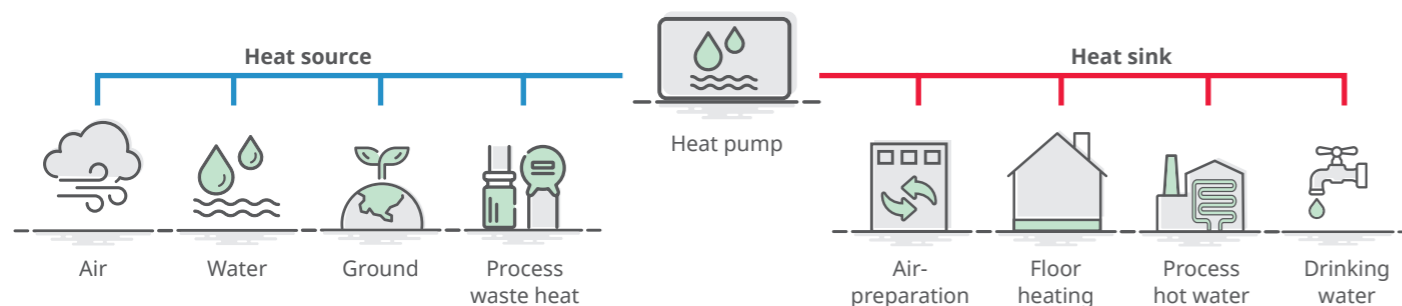

Possible heat sources

Air (aerothermic)

The heat is extracted from the ambient air by means of an outdoor unit.

Water (hydrothermal)

Groundwater and surface water can also be exploited as heat sources via wells or collectors.

Ground (geothermal)

Via near-surface collectors or a probe, the heat is extracted from the ground.

Process

Industrial waste heat or heat from other refrigerant systems can be utilized optimally with a heat pump.

Customized heat solutions up to 3,2 MW



Air-to-water
up to 77 °C
up to 1,100 kW



Water-to-water
up to 100 °C
up to 3,200 kW

2G afilea large-scale heat pumps are available as air-to-water and water-to-water units. As a result, a wide range of different types of existing heat sources can be exploited – including in combination (Booster technology).

Even in single-stage version, our water-to-water heat pumps can achieve temperature strokes of up to 70 K. For applications with higher temperature strokes, two-stage concepts are possible – right up to project-specific special solutions with flow temperatures from 90 °C to 130 °C.

Our auxiliary equipment

Acoustic enclosure for outdoor installation

- Modular sound insulation walls
- Esthetic, form-fitting design
- Sturdy aluminum frame construction
- Internally screwed corner connectors
- 45dB(A) at 10 meters sound pressure



Machine space replacement enclosure (protective and acoustic enclosure)

- Frame made of aluminum profiles
- 1.5 mm sheet steel outside
- 50 mm fiberglass panels, non-combustible (building material class B1 or better)
- Easy service access through wing doors and removable panels
- ATEX certified ventilation
- Integrated temperature sensors
- Compliant with PED and DS/EN 378, Site classification III
- 20 dB(A) at 10 meters



Comprehensive container concept

- Container and sound protection solutions
- Individual, ready-to-connect equipment
- Flexible installation depending on site and soundproofing requirements
- Can be integrated into existing buildings and central heating systems
- 45dB(A) at 10 meters



Our portfolio

Water-to-water heat pumps

R513a

R1234ze



afilia water C-B-r
62 kW_{th} to 388 kW_{th}

R717



afilia water C-S-r
534 kW_{th} to 2,287 kW_{th}

R717



afilia water C-G-r
837 kW_{th} to 3,128 kW_{th}

R600a



afilia water C-B-sc
285 kW_{th} to 1,360 kW_{th}

R717

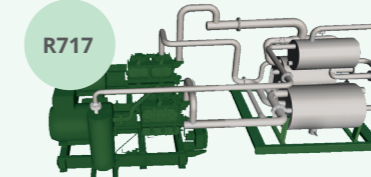

afilia water D-SG-r
607 kW_{th} to 2,492 kW_{th}

Air-to-water heat pumps

R290



afilia air M-sl-AEK
89 kW_{th} to 888 kW_{th}
afilia air M-sl-PEK
87 kW_{th} to 866 kW_{th}

R290



afilia air M-sl3-AEK
108 kW_{th} to 1,080 kW_{th}

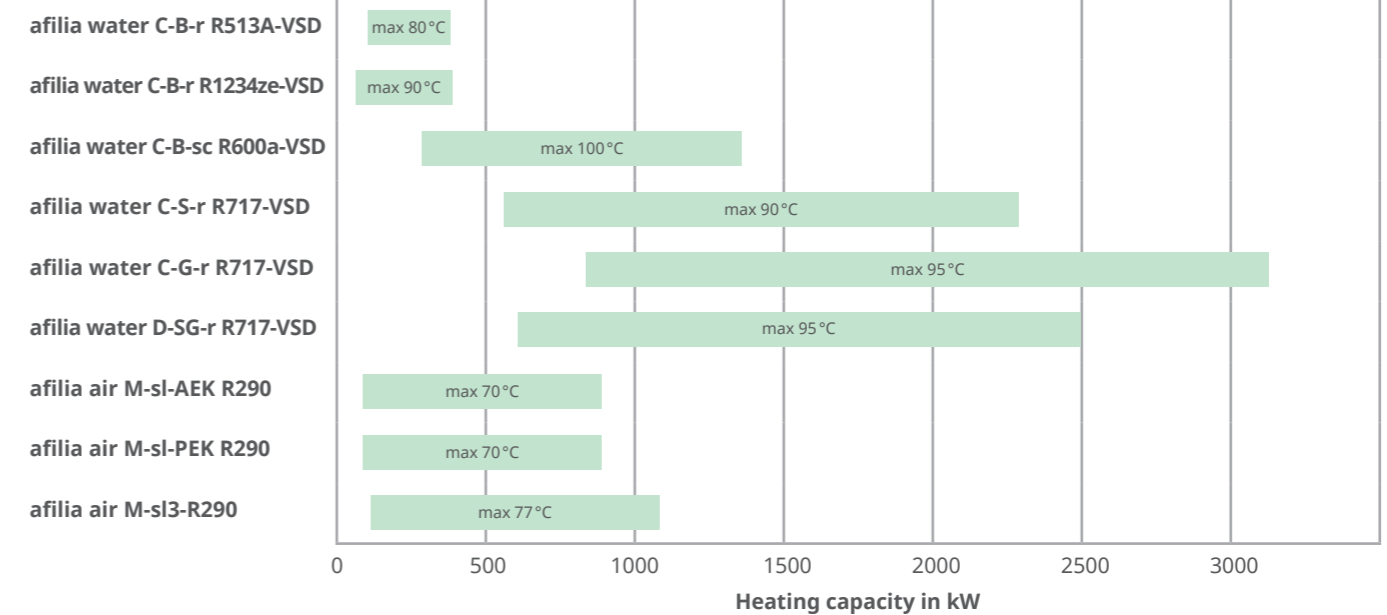



Water-to-water heat pump

FACTS:



Refrigerant:
R513A
R1234ze



Heating capacity:
62 kW to 388 kW



Weight:
1,700 kg to 1,950 kg

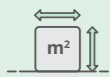

Dimensions:
Height 1,785 mm
Length 2,700 mm
Width 920 mm



Supply temperature:
Up to 90°C in single-stage



Application:
Industrial and commercial applications

The current data can be found here:

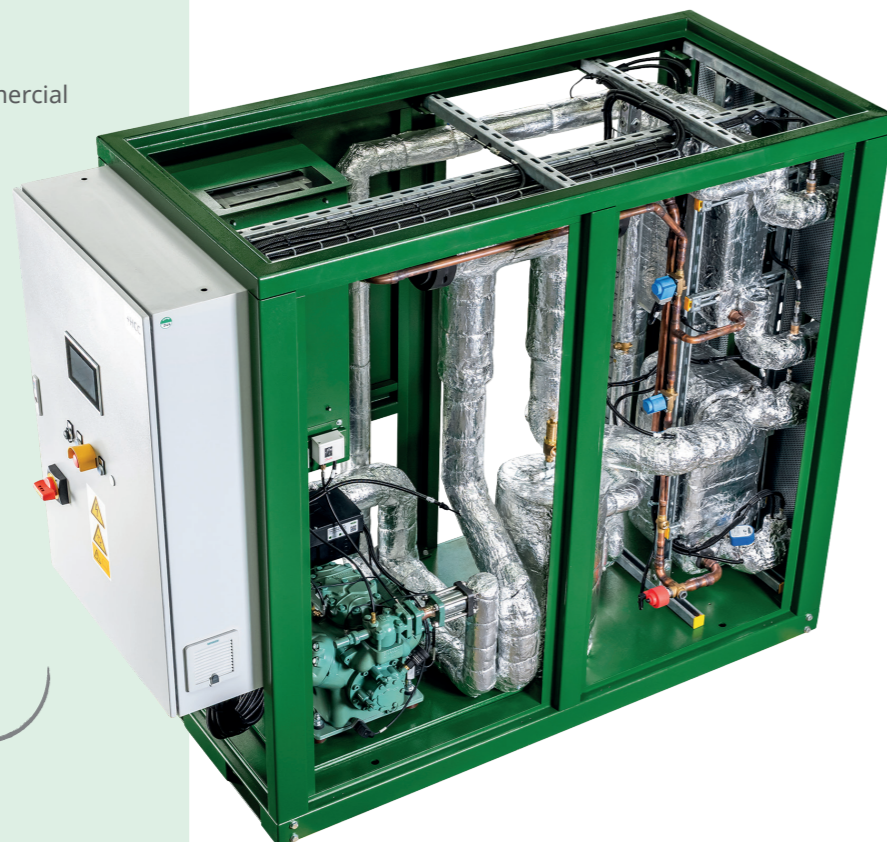

afilia water C-B-r R513A/ R1234ze-VSD

FEATURES:

Supply temperatures up to 90°C in the single-stage process

Ideal for industrial applications with low source temperatures and high heat demand (e.g. process heat, district heating, drying)

Variable Speed Drive (VSD)

Automatic adaptation of power to current demand – high efficiency in partial load operation and reduced energy consumption

Designed for high temperature differences in the heating circuit 20K

Improved energy utilization and optimal integration into existing heat distribution networks or industrial processes

Ventilated, A2L-safe housing (R1234ze)

Highest operational safety and compliance with all current safety and environmental standards

Very high COP and SPF

Significantly lower operating costs and shorter payback time compared to traditional systems

Fitted with one or two reciprocating compressors

Adapted to the required heat output

Modular design

Several units can be combined to increase the heating capacity to up to 1,000 kW

Further advantages of a 2G product can be found on page 5!

afilia water C-B-r R513A-VSD

Type	Heating capacity	COP	Power consumption	Source in/out	Sink in/out
C-80-B-r-6-L	104 kW	2.72	37 kW	10/5	60/80
C-80-B-r-6-2S	154 kW	2.76	54 kW	10/5	60/80
C-80-B-r-6-2L	207 kW	2.69	75 kW	10/5	60/80
C-80hts-B-r-6-L	192 kW	3.78	49 kW	30/25	60/80
C-80hts-B-r-6-2S	296 kW	3.79	76 kW	30/25	60/80
C-80hts-B-r-6-2L	380 kW	3.75	99 kW	30/25	60/80

Heating capacity and power consumption according to (EN14511)

GWP F-Gas-VO₅: 629

afilia water C-B-r R1234ze -VSD

Type	Heating capacity	COP	Power consumption	Source in/out	Sink in/out
C-90-B-r-6-L	62 kW	2.40	26 kW	10/5	70/90
C-90-B-r-6-2S	95 kW	2.54	38 kW	10/5	70/90
C-90-B-r-6-2L	124 kW	2.39	52 kW	10/5	70/90
C-90hts-B-r-6-L	199 kW	3.92	51 kW	45/40	70/90
C-90hts-B-r-6-2S	304 kW	3.95	77 kW	45/40	70/90
C-90hts-B-r-6-2L	388 kW	3.88	100 kW	45/40	70/90

Heating capacity and power consumption according to (EN14511)

GWP F-Gas-VO₅: 1,37

All information and illustrations are non-binding. Subject to technical changes.



Water-to-water heat pump

FACTS:



Refrigerant:
R600a, GWP 3



Heating capacity:
285 kW to 1,360 kW



Weight:
3,200 kg to 5,000 kg

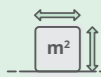

Dimensions:
Height 2,200 mm to 2,500 mm
Length 3,200 mm to 4,300 mm
Width 940 mm to 1,275 mm



Supply temperature:
Up to 100 °C



Application:
Demanding high-temperature applications

The current data can be found here:

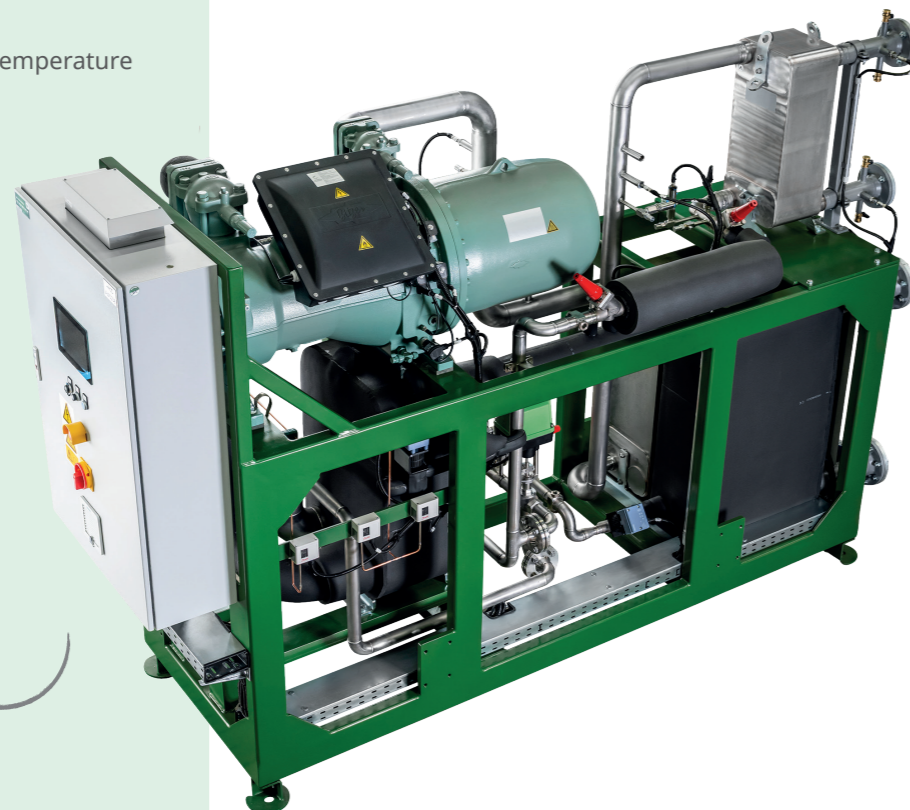

afilia water C-B-sc R600a-VSD

FEATURES:

Natural refrigerant R600a (isobutane, GWP 3)

Sustainable, environmentally friendly operation with maximum safety

Designed for demanding high temperature applications

Optimal use of low-temperature waste heat with high efficiency

Temperature rise up to 85 K

Setting standards in this performance class

Hot water production up to 100°C

Ideal for industrial process heat and district heating applications

Integrated desuperheater, condenser and subcooler unit

High COP and increased overall efficiency

Compact design with low refrigerant charge

Easy integration into existing systems

Further advantages of a 2G product can be found on page 5!

afilia water C-100-B-sc R600A-VSD

Type	Heating capacity	COP	Power consumption	Source in/out	Sink in/out
C-100-B-sc-8593	285 kW	2.28	125 kW	20/15	80/100
C-100-B-sc-8593	425 kW	3.02	141 kW	35/30	80/100
C-100-B-sc-8593	635 kW	4.15	153 kW	50/45	80/100
C-100-B-sc-95113	587 kW	2.30	255 kW	20/15	80/100
C-100-B-sc-95113	915 kW	3,02	303 kW	35/30	80/100
C-100-B-sc-95113	1,360 kW	4.11	331 kW	50/45	80/100

Heating capacity and power consumption according to (EN14511)

GWP F-Gas-VOs: 3



Water-to-water heat pump

FACTS:



Refrigerant:
R717



Heating capacity:
534 kW to 2,287 kW



Weight:
6,950 kg to 12,330 kg

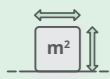

Dimensions:
Height 2,830 mm
Length 6,300 mm to 7,300 mm
Width 1,200 mm



Supply temperature:
Up to 90 °C



Application:
Industrial and commercial applications

afilia water C-S-r R717-VSD

The current data can be found here:

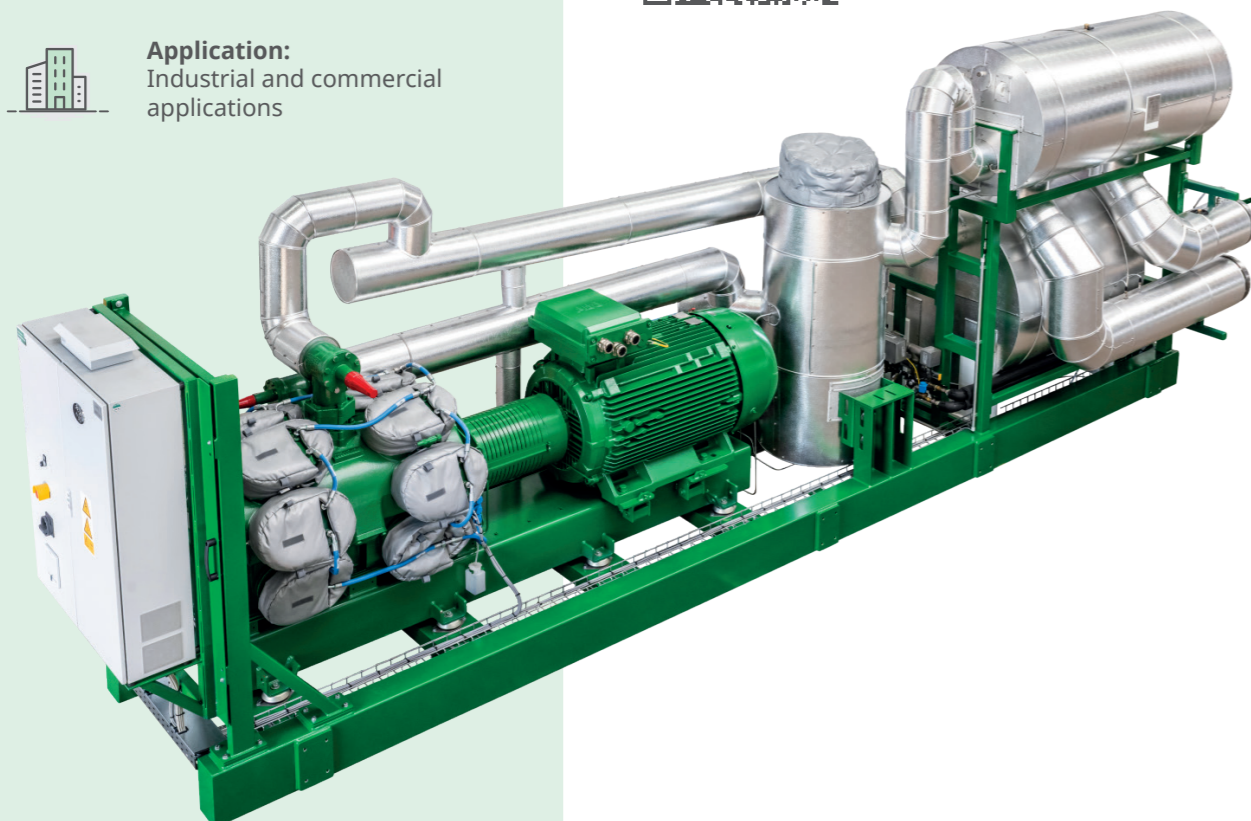

FEATURES:

Natural refrigerant ammonia with very low GWP (Global Warming Potential)

Particularly environmentally friendly, energy-efficient and F-gas-free – meets the highest sustainability requirements with maximum performance

Variable speed drive for precise power adjustment in partial load operation

Consistently optimal efficiency and reduced energy costs – perfect efficiency with changing load profiles

Reaches flow temperatures up to 90°C and enables large temperature strokes

Highest efficiency even in demanding industrial and process applications with large temperature difference between source and sink

Integrated system control

Control of heat pump, power take offs and components – easy control, optimal coordination, less installation effort

Use of robust open-reciprocating compressors with 400V or 690V motors

Durable, easy to maintain and with excellent partial-load performance – ideal for high performance requirements in industry.

Heating capacities from 500 kW to 2,300 kW, optional modular combination

Flexible adaptation to a wide range of applications – from district heating systems to industrial process heat

Two-stage efficiency increase possible

By combining two optimally matched models – one lower and one upper stage – a large temperature difference between the source and sink can be achieved. The afilia water C-G-r-series VSD-R717 also supports this two-stage operation, enabling maximum efficiency with high temperature requirements.

Flexible setup

Separation of heat exchanger and compressor/motor combination

Further advantages of a 2G product can be found on page 5!

afilia water C-S-r R717-VSD

Type	Heating capacity	COP	Power consumption	Source in/out	Sink in/out
C-50-S-r-06L	562 kW	4.60	122 kW	10/5	35/50
C-50-S-r-08L	750 kW	4.60	162 kW	10/5	35/50
C-50-S-r-12L	1,123 kW	4.60	244 kW	10/5	35/50
C-50-S-r-16L	1,498 kW	4.60	325 kW	10/5	35/50
C-70-S-r-06	847 kW	5,32	159 kW	30/25	50/70
C-70-S-r-08	1,142 kW	5.32	214 kW	30/25	50/70
C-70-S-r-12	1,716 kW	5.32	322 kW	30/25	50/70
C-70-S-r-16	2,287 kW	5.32	429 kW	30/25	50/70
C-90-S-r-06	534 kW	4.55	117 kW	40/35	65/90
C-90-S-r-08	715 kW	4.55	157 kW	40/35	65/90
C-90-S-r-12	1,072 kW	4.55	235 kW	40/35	65/90
C-90-S-r-16	1,427 kW	4.55	313 kW	40/35	65/90

Heating capacity and power consumption according to (EN14511)

GWP F-Gas-VO₅: 0



Water-to-water heat pump

FACTS:



Refrigerant:
R717



Heating capacity:
837 kW to 3,128 kW



Weight:
8,620 kg to 8,900 kg



Dimensions:
Height 2,830 mm
Length 7,000 mm to 8,000 mm
Width 1,750 mm



Supply temperature:
Up to 95 °C



Application:
Industrial and commercial applications

afilia water C-G-r R717-VSD

The current data can be found here:

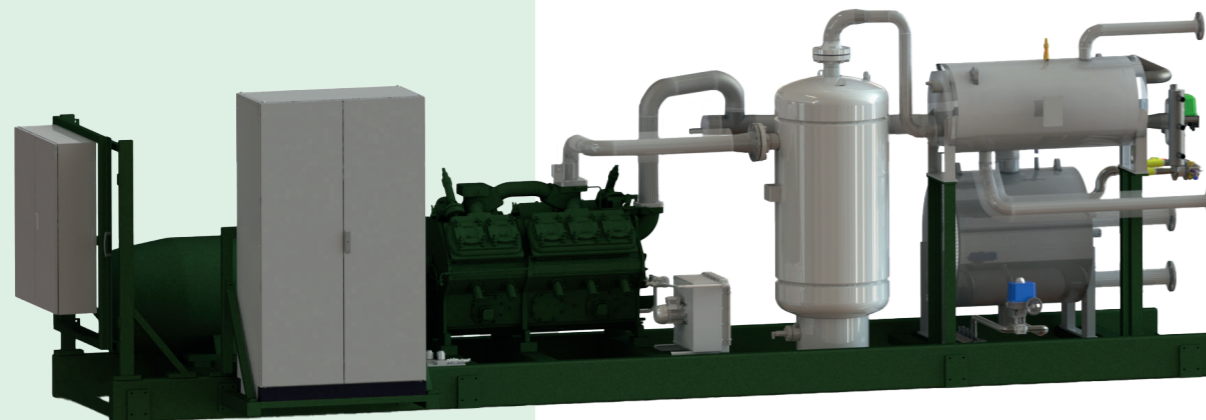

FEATURES:

Natural refrigerant ammonia with very low GWP (Global Warming Potential)

Particularly environmentally friendly, energy-efficient and F-gas-free – meets the highest sustainability requirements with maximum performance

Variable speed drive for precise power adjustment in partial load operation

Consistently optimal efficiency and reduced energy costs – perfect efficiency with changing load profiles

Reaches flow temperatures up to 95°C and enables large temperature strokes

Highest efficiency even in demanding industrial and process applications with high temperature difference between source and sink

Integrated system control

Control of heat pump, power take offs and components – easy control, optimal coordination, less installation effort

Use of robust open-reciprocating compressors with 400V or 690V motors

Durable, easy to maintain and with excellent partial-load performance – ideal for high performance requirements in industry

Heating capacities from 500 kW to 3,200 kW, optional modular combination

Flexible adaptation to a wide range of applications – from district heating systems to industrial process heat

Two-stage efficiency increase possible

By combining two optimally matched models – one lower and one upper stage – a large temperature difference between the source and sink can be achieved. The afilia water C-S-r-series VSD-R717 also supports this two-stage operation, enabling maximum efficiency at high temperature requirements.

Flexible setup

Separation of heat exchanger and compressor/motor combination

Further advantages of a 2G product can be found on page 5!

afilia water C-G-r R717-VSD

Type	Heating capacity	COP	Power consumption	Source in/out	Sink in/out
C-50-G-r-700	837 kW	4.14	202 kW	10/5	38/58
C-50-G-r-1100	1,257 kW	4.15	303 kW	10/5	38/58
C-50-G-r-1400	1,677 kW	4.15	404 kW	10/5	38/58
C-50-G-r-1800	2,096 kW	4.15	505 kW	10/5	38/58
C-95-G-r-350	1,250 kW	5.21	240 kW	48/43	65/95
C-95-G-r-550	1,875 kW	5.19	361 kW	48/43	65/95
C-95-G-r-750	2,503 kW	5.19	482 kW	48/43	65/95
C-95-G-r-950	3,128 kW	5.20	602 kW	48/43	65/95

Heating capacity and power consumption according to (EN14511)

GWP F-Gas-VO₅: 0



Water-to-water heat pump

FACTS:



Refrigerant:
R717



Heating capacity:
607 kW to 2,492 kW



Weight:
12,120 kg to 34,350 kg



Dimensions:
Height 2,830 mm
Length 6,500 mm to 8,500 mm
Width 2,860 mm to 3,900 mm



Supply temperature:
Up to 95 °C



Application:
Industrial and commercial applications

afilia water D-SG-r R717-VSD

The current data can be found here:

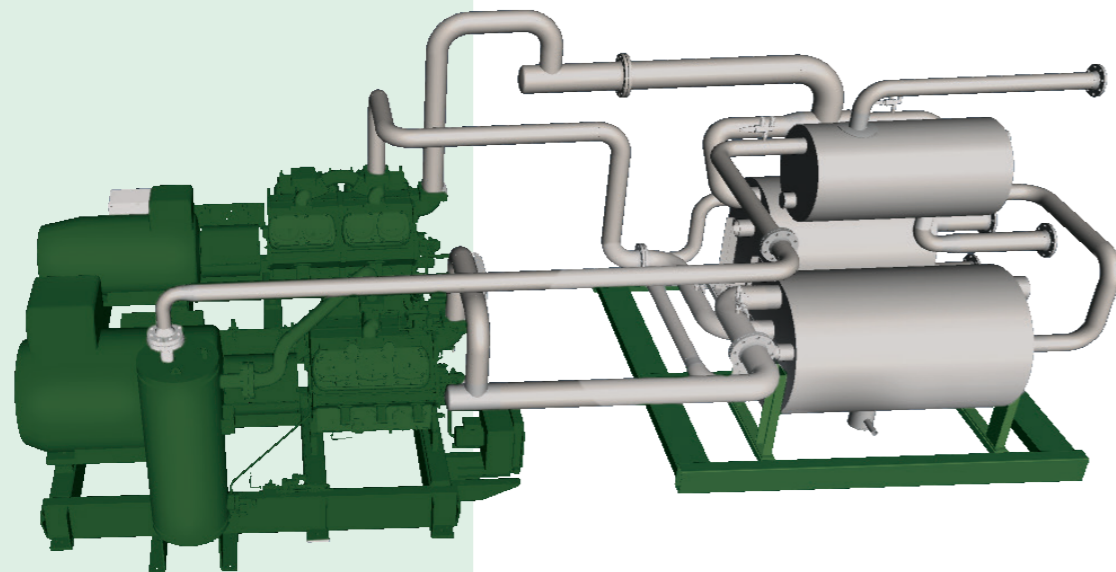

FEATURES:

Natural refrigerant ammonia with very low GWP (Global Warming Potential)

Particularly environmentally friendly, energy-efficient and F-gas-free – meets the highest sustainability requirements with maximum performance

Variable speed compressor drive for demand-based power control

Maximum energy efficiency over the entire operating range – particularly economical in partial load and changing process conditions

Reaches flow temperatures up to 95°C and enables large temperature strokes

Highest efficiency even in demanding industrial and process applications with high temperature difference between source and sink

Combination of low-pressure and high-pressure stage in a modular system

High temperature stroke in a compact design, ideal for district heating, industrial process heat and geothermal cooling applications

Use of robust open-reciprocating compressors with 400V or 690V motors

Durable, easy to maintain and with excellent partial load characteristics – ideal for high performance requirements in industry.

Separation of heat exchanger and compressor/motor unit for modular flexibility

Simplified maintenance, quick accessibility and minimized downtime for service or repair

Further advantages of a 2G product can be found on page 5!

afilia water D-SG-r R717-VSD

Type	Heating capacity	COP	Power consumption	Source in/out	Sink in/out
D-95-SG-r-06-08	607 kW	2.80	217 kW	10/5	65/95
D-95-SG-r-08-350	974 kW	2.86	341 kW	10/5	70/90
D-95-SG-r-16-550	1,562 kW	2.55	613 kW	3/-2	65/95
D-95-SG-r-11-550	2,865 kW	3.68	778 kW	30/25	70/90
D-95-SG-r-18-950	2,492 kW	2.82	884 kW	6/1	65/95

Heating capacity and power consumption according to (EN14511)

GWP F-Gas-VOs: 0



Air-to-water heat pump

FACTS:



Refrigerant:
R290



Heating capacity:
89 kW



Weight per module:
840 kg

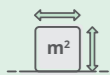

Dimensions per module:
Height 2,450 mm
Length 2,560 mm
Width 1,100 mm



Supply temperature:
Up to 70 °C



Application:
For high heating capacities
or cooling



LOW Noise version

The current data can be found here:



afilia air M-sl-AEK R290



FEATURES:

Combination of up to ten units with independent refrigeration circuits

Flexible power adaptation to changing requirements – perfectly scalable for projects of any size, from commercial to industrial. Maintenance or service on one unit can be performed without interrupting the operation of the others.

Use of natural refrigerant propane (R290) with minimum capacity per module

Environmentally friendly, future-proof and F-Gas compliant – maximum performance with minimal environmental footprint

Operation down to -20°C outside temperature and supply temperatures up to 75°C through state-of-the-art scroll compressor technology Efficient heating and cooling even under extreme conditions – ideal for applications with high temperature requirements.

Further advantages of a 2G product can be found on page 5!

afilia air M-sl-AEK R290

2-wire heat pump
Heating or cooling Heat optimized

Type	Heating capacity	COP	Power consumption	Water temperature in/out	Sound power in dB(A)
AEK-R290-1	89 kW	3.98	22 kW	30/35	in dB(A)
AEK-R290-2	178 kW	3.95	45 kW	30/35	84,5
AEK-R290-3	266 kW	3.98	67 kW	30/35	86,3
AEK-R290-4	355 kW	3.98	89 kW	30/35	87,5
AEK-R290-5	444 kW	3.98	112 kW	30/35	88,5
AEK-R290-6	533 kW	3.98	134 kW	30/35	89,3
AEK-R290-7	622 kW	3.98	156 kW	30/35	90,0
AEK-R290-8	710 kW	3.98	178 kW	30/35	90,5
AEK-R290-9	799 kW	3.98	201 kW	30/35	91,0
AEK-R290-10	888 kW	3.98	223 kW	30/35	91,5

Medium: Water temperature in/out: 30/35°C – Outdoor air temperature 7°C Heating capacity and power consumption according to (EN14511)

GWP F-Gas-VO₂: 3

Operating limits

in °C

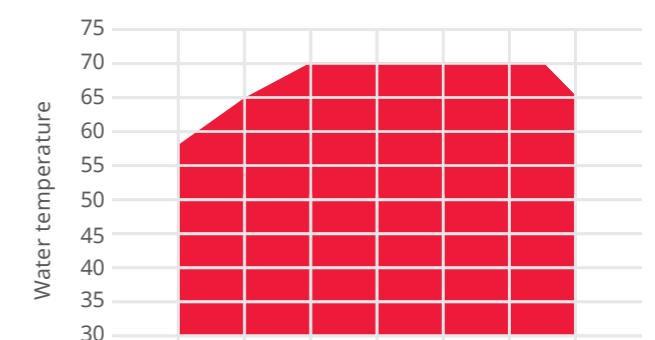
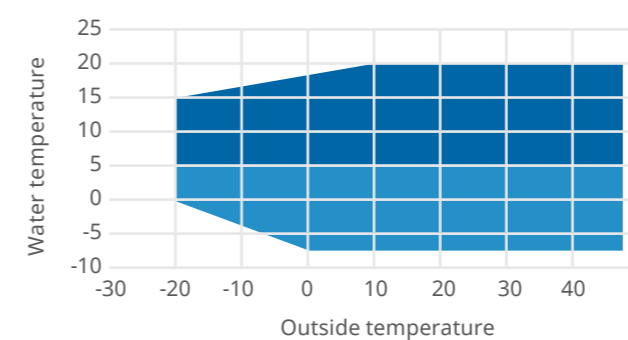

■ Cooling mode | ■ Cooling mode with glycol | ■ Heating



Air-to-water heat pump

FACTS:



Refrigerant:
R290



Heating capacity per module:
87 kW



Weight per module:
840 kg



Dimensions per module:
Height 2,450 mm
Length 2,560 mm
Width 1,100 mm



Supply temperature:
Up to 70 °C



Application:
For high heating capacities
and simultaneous cooling



4-wire heat pump
Heating and cooling
possible simultaneously

The current data can be found here:



afilia air M-sl-PEK R290



FEATURES:

Combination of up to ten units with independent refrigeration circuits

Flexible power adaptation to changing requirements – perfectly scalable for projects of any size, from commercial to industrial. Maintenance or service on one unit can be performed without interrupting the operation of the others.

Use of natural refrigerant propane (R290) with minimum capacity per module

Environmentally friendly, future-proof and F-Gas compliant – maximum performance with minimal environmental footprint

Operation down to -20°C outside temperature and supply temperatures up to 75°C through state-of-the-art scroll compressor technology Efficient heating and cooling even under extreme conditions – ideal for applications with high temperature requirements.

Further advantages of a 2G product can be found on page 5!

afilia air M-sl-PEK R290

Type	Heating capacity	COP	Power consumption	Water temperature in/out
PEK-R290-1	87 kW	3.88	22 kW	30/35
PEK-R290-2	173 kW	3.88	45 kW	30/35
PEK-R290-3	260 kW	3.88	67 kW	30/35
PEK-R290-4	346 kW	3.88	89 kW	30/35
PEK-R290-5	433 kW	3.88	112 kW	30/35
PEK-R290-6	520 kW	3.88	134 kW	30/35
PEK-R290-7	606 kW	3.88	156 kW	30/35
PEK-R290-8	693 kW	3.88	178 kW	30/35
PEK-R290-9	779 kW	3.88	201 kW	30/35
PEK-R290-10	866 kW	3.88	223 kW	30/35

Medium: Water temperature in/out: 30/35°C – Outdoor air temperature 7°C Heating capacity and power consumption according to (EN14511)

GWP F-Gas-VO: 3

Operating limits

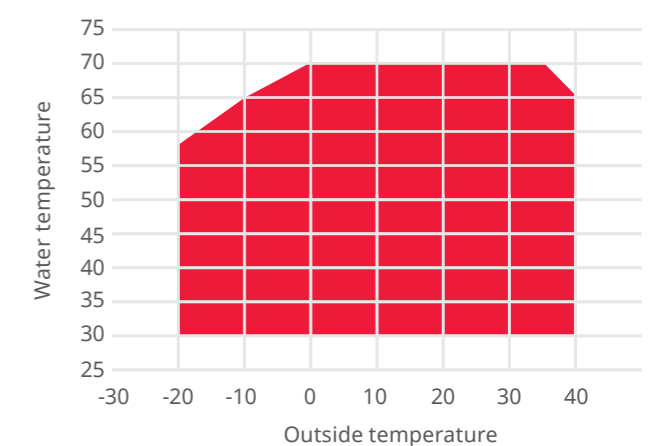
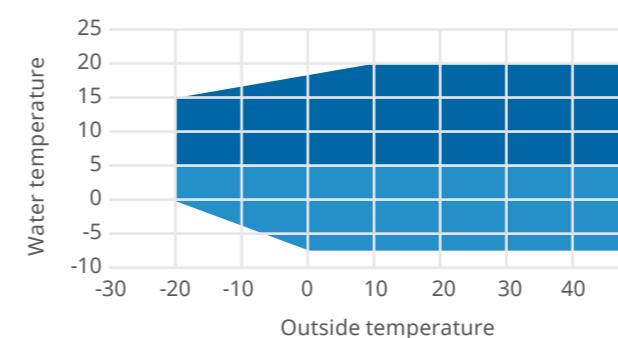

■ Cooling mode | ■ Cooling mode with glycol | ■ Heating



Air-to-water heat pump

FACTS:



Refrigerant:
R290



Heating capacity per module:
108 kW



Weight per module:
845 kg



Dimensions per module:
Height 2,450 mm
Length 2,560 mm
Width 1,100 mm



Supply temperature:
Up to 77 °C



Application:
For high heating capacities
or cooling



LOW Noise version

afilia air M-sI3-AEK R290

The current data can be found here:



FEATURES:

Combination of up to ten units with independent refrigeration circuits

Flexible power adaptation to changing requirements – perfectly scalable for projects of any size, from commercial to industrial. Maintenance or service on one unit can be performed without interrupting the operation of the others.

Use of natural refrigerant propane (R290) with minimum capacity per module

Environmentally friendly, future-proof and F-Gas compliant – maximum performance with minimal environmental footprint

Operation down to -20°C outside temperature and supply temperatures up to 75°C through state-of-the-art scroll compressor technology Efficient heating and cooling even under extreme conditions – ideal for applications with high temperature requirements.

Further advantages of a 2G product can be found on page 5!

afilia air M-sI3-AEK R290

2-wire heat pump
Heating or cooling Heat optimized

Type	Heating capacity	COP	Power consumption	Water temperature in/out	Sound power in dB(A)
AEK-R290-1	108 kW	3.97	27 kW	30/35	82,3
AEK-R290-2	216 kW	3.97	54 kW	30/35	85,3
AEK-R290-3	324 kW	3.97	82 kW	30/35	87,1
AEK-R290-4	432 kW	3.97	109 kW	30/35	88,3
AEK-R290-5	540 kW	3.97	136 kW	30/35	89,3
AEK-R290-6	648 kW	3.97	163 kW	30/35	90,1
AEK-R290-7	756 kW	3.97	190 kW	30/35	90,8
AEK-R290-8	864 kW	3.97	218 kW	30/35	91,3
AEK-R290-9	972 kW	3.97	245 kW	30/35	91,8
AEK-R290-10	1080 kW	3.97	272 kW	30/35	92,3

Medium: Water temperature in/out: 30/35°C – Outdoor air temperature 7°C Heating capacity and power consumption according to (EN14511)

GWP F-Gas-VO: 3

Operating limits

in °C

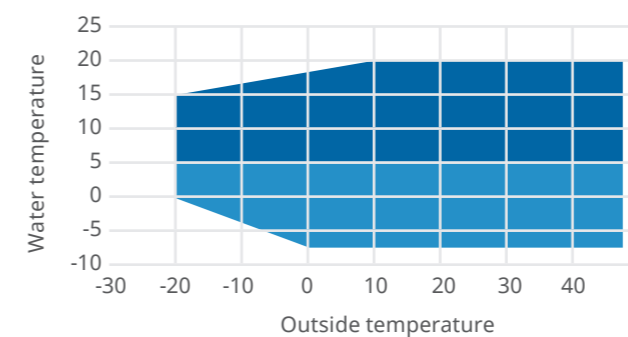

■ Cooling mode | ■ Cooling mode with glycol | ■ Heating

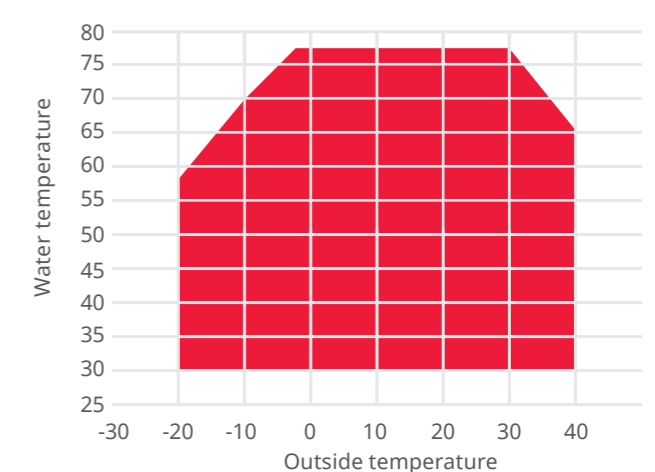

Important information for the refrigerant R-290 (propane)

The following information provides guidance for the planning and installation of outdoor heat pumps with the refrigerant R-290 (propane).

This refrigerant must be prevented from entering a building or otherwise causing hazards.

Outdoor installation with refrigerant R-290

Propane is a flammable gas with a relative density to air of 1.55. It is therefore a "heavier" gas than air and falls downwards.

In the case of structures that are outdoors, no gas mist can be generated upwards.

For this reason, the refrigerant R-290 can only be used in air-to-water heat pumps installed outdoors.

In the case of heavy gases, there is a high probability that they can accumulate in the lower area, thus **posing a fire or explosion hazard in this area.**

Properties of R-290 (propane)

- Chemical formula: C₃H₈ REMOTE MAINTENANCE
- Normal boiling point: -42.1 °C
- Flammability from temperature: -104 °C
- Relative density (to air): 1.55 at 20°C
- Auto-ignition temperature: +470 °C
- Molar mass: 44.1 g/mol
- Lower explosion limit: 1.5 Vol. - %
- Safety group according to EN 378-1: A3
- Temperature class (explosion protection): T1 (max. +450 °C)

Recurring tests

Commercial refrigeration and heat pump systems are often also pressure systems requiring monitoring within the meaning of the German Ordinance on Industrial Safety. The following applies to pressure systems requiring

monitoring:

- Section 15 BetrSichV regulates the inspection before commissioning and before recommissioning after a change subject to inspection.
- Section 16 BetrSichV regulates the recurring inspections.
- BetrSichV Annex 2, Section 4 specifies inspection periods and inspection responsibilities for pressure equipment and system parts.

System inspections must be carried out by an accredited inspection body (ZÜS) every 5 years if the inspection of a plant part must be carried out by an ZÜS.

Leak tests

When flammable refrigerants are used, it is recommended for safety reasons to carry out a leak test at least 2 times a year (and at the same time a visual check for harmful vibrations, e.g. in the piping).

Emergency measures catalog

The operator must develop and continuously update an emergency measures catalog in the event of a leak of flammable refrigerant and oil or for the brines and heat transfer fluids used.

In addition, the operator is obliged to coordinate the safety measures for service work by different companies on the operator's premises!

If hazardous situations can also arise beyond the operating site's limits, the heat pump operator must also provide for relevant safety measures and, if necessary, agree coordination of measures and responsibilities with the neighborhood.

Transport and storage of heat pumps

The heat pumps are delivered filled. The machine must be checked for any damage.

The temperature limits of +5°C to +52°C ambient temperature must be observed for temporary storage of the machine. The installation area and its surroundings must be clearly demarcated and marked for unauthorized access.

The signs below must be clearly visible at all access points on site.

Checking the installation conditions

Already when procuring work equipment and also heat pumps, the operator must carry out a "risk assessment" in accordance with Section 3 of the German Ordinance on Industrial Safety and Health (BetrSichV). As part of the risk assessment, the operator must also determine or specify the inspection intervals for the recurring inspection of refrigeration systems.

The operator must also define occupational health and safety measures with the risk assessment. When using flammable refrigerants in heat pumps, these measures must be taken by the operator, taking into account the special requirements of the fire and explosion protection.

For heat pumps installed outdoors with flammable refrigerants, the minimum safety distances to potential ignition sources, access restrictions, their identification and the qualification of operation and service personnel required by the manufacturer must be taken into account.

Depending on the installation situation, refrigerant that has escaped due to leaks can, in flammable concentration, collect in recesses, troughs, light and installation shafts below the refrigeration machines. In these cases, in accordance with DIN EN378-3, Section 4.3, ventilation measures and/or gas alarm units must be used to mitigate danger.

Further information in VDMA 24020-3.

Setup and installation

Observe the following points when installing a 2G afillia heat pump with R-290 (propane)

- According to the manufacturer, the refrigeration machines may only be installed outdoors and in well-ventilated installation areas.
- It is strictly forbidden to install the heat pumps inside a building, basement, garage or partly enclosed environment contrary to the manufacturer's specifications.
- If other technical units are installed in the immediate vicinity, a minimum safety distance of 2 m must be maintained at the installation location of the refrigeration machines on the long side and 1 m on the front side.
- This distance is absolutely necessary in order to guarantee the ventilation of the compressor section and to avoid counterflows or turbulence with other technical units.
- If the refrigeration machines are installed on a free surface so that unauthorized or untrained persons could also have access to the refrigeration machines, a protective grille, protective fence or protective wall must be provided:
 - Protective fence:** min. 2.70 m high and with a locked entry point. All sides must be clearly marked with the signs shown in this document. The protective fence must be min. 2 m away from the machine.
 - Protective wall:** min. 2.70 m high and with a locked entry point. All sides must be clearly marked with the signs shown in this document. Correct air circulation must be guaranteed on all sides to prevent backflow or turbulences. A minimum distance of 3.00 m must be maintained on all sides.
- Only personnel specially trained for A3 refrigerants (according to EN 13313) are permitted to carry out activities. Untrained persons/operators must stay out of the safety distance of the machine.
- Make sure that there are no ignition sources in the immediate vicinity of the coolant venting system.
- An acoustic and visual signal must be installed on site to signal the status of the gas sensor used.

Ex-Zone 2

The requirements for Ex zone 2 must be taken into account for the environment of the outlet of the discharge line of the safety valves and the ventilation openings of condenser sections according to the manufacturer's specifications.

Only instructed persons are allowed access to this area. It should only be possible to enter Ex Zone 2 areas through secured and marked access points.

All access points must be designed as escape and rescue routes.

They must be permanently monitored and secured against misuse via electromechanical safety devices (escape route safety systems).

Refrigerant leaks into connected systems due to leaks in heat exchangers must be taken into account

- Leaks in the heat exchanger of the refrigeration machine can cause the refrigerant to leak into the connected coolant circuit.
- To ensure that the refrigerant that has entered can escape safely from the coolant circuit again, the automatic bleeders of the coolant circuit must ensure that the refrigerant that has entered is safely discharged into the open air. Also for these blow-off lines, the same requirements apply as for the blow-off lines of the safety valves.
- If necessary, it may be helpful to equip the blow-off lines with gas detection so that information or warnings about leaks in the heat exchanger are provided at an early stage.

Gaps to be taken into account

Distances to be observed for single installation

Please also observe the maintenance and operating instructions for the machines or the hazard assessments/ explosion protection documents prepared by the operator/ system installer.

Maintenance and repair directives

All persons working on heat pumps with flammable refrigerants must be familiar with the safety aspects to be observed when handling flammable refrigerants and must be able to demonstrate appropriate training. 2G Service employees meet these requirements and are familiar with the work instructions required to carry out the work safely and are equipped with the necessary tools and safety equipment.

Recommendations for wall distances

If there are obstacles in the vicinity of the system that are half the system height, the distance of this obstacle from the system must be at least equal to the height of the obstacle.

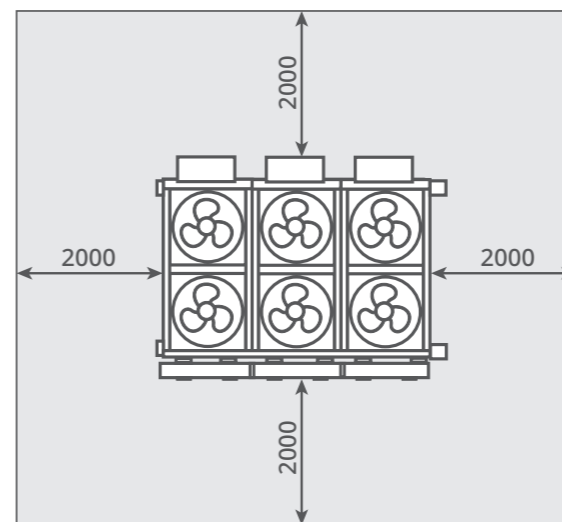

The minimum distance of 1.50 m must also be maintained. Recommended distance for railings with a height of 1 m, at least 1.5 m.

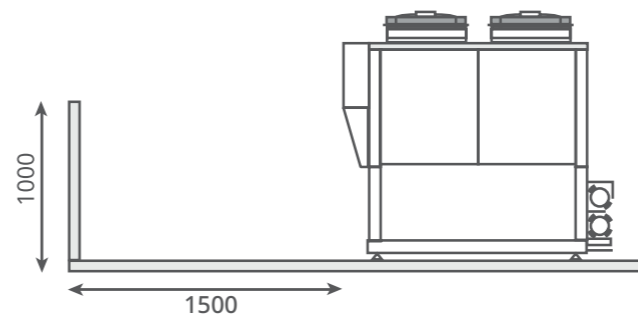

Technical minimum spaces

Technical minimum spaces per unit

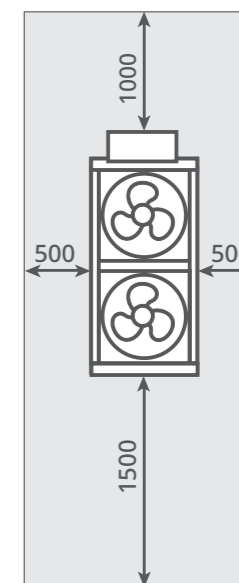

Technical spaces of the modular system

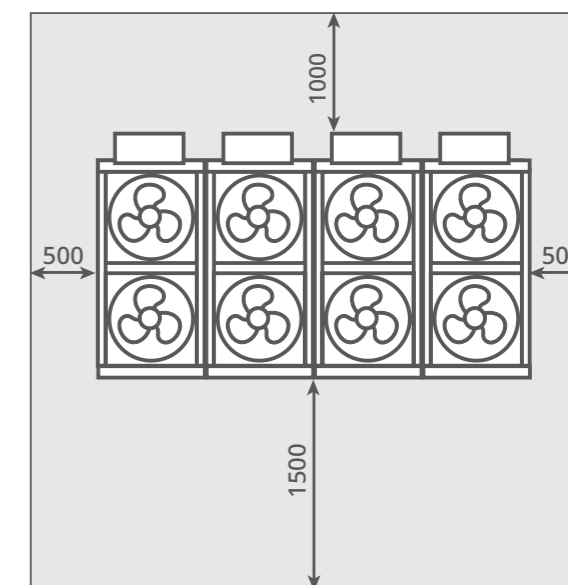

Alternatives

Alternatively, the following can be planned:

- Installing roof siphons
- Closing or replanning inlets
- Retrofitting siphons for assembly on existing systems
- Equipping rooflight domes with NC or NO motors

Service

Quick and reliable. 24/7 worldwide

In person or digitally: 2G Service makes sure that your heat pump always operates reliably – and that you can focus on your core business

As a Full-Service provider, we always keep tabs on everything that matters to you. You do not have to take care of anything else. Our products and services originate from a single source and are therefore seamlessly integrated – which saves time and money, thus providing a low total cost of ownership.

At 2G, we believe that it should be as easy as possible to operate your own CHP. We minimise downtimes, and other irregularities. Therefore, we offer you way more than only a modern combined heat and power system. We, as the manufacturer, want to relieve you as an operator and sustainably maximize the availability of your system - and your satisfaction with our product in turn.



Service-Facts

>150

Customer-oriented service technicians in Germany

>1.000

Technicians in the network worldwide

>200

Service partners worldwide



24/7

Servicehotline

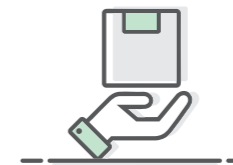

Excellent parts availability from all manufacturers



6.000m²

Service central warehouse

Intelligent flow prediction in conjunction with the 2G AI „I.R.I.S.“



Many spare parts are available within

24h

(within Germany)



Remote commissioning through AR

>75%

of error messages are resolved remotely

Services and Service Products

With our technical components, you have the option of operating your heat pump in compliance with legal requirements at all times, effectively preventing signs of wear and tear, and thus ultimately increasing the overall efficiency of your system. Upon request, 2G will keep track of all measurement intervals, limit values, and documentation requirements for you, so you can focus on important matters.

Manufacturer independent



Products

- Spare parts
- 2G Premium Parts
- Compressor
- Replacement and new engines
- Lubricating oil
- Refrigerant

Services

- Plant service
- System check
- Leak test
- DGUV test
- Engine repair
- Compressor Maintenance
- Control conversion
- System conversions and upgrades to 2G technology

Network of service technicians

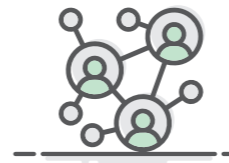

We can draw on a vast network of highly trained specialists who, as service technicians, can be at your location in no time and ensure the smooth operation of your system. Our fleet of service vehicles is equipped with everything that is required to analyze, maintain, and repair a CHP.

Original spare parts

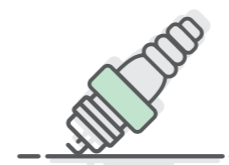

We exclusively use original 2G spare parts or spare parts of renowned manufacturers. This way, we can guarantee that the elevated quality, operational safety, and efficiency of your 2G system are preserved. Thanks to a well-organized, central spare parts depot and state-of-the-art logistics, the rapid availability of your spare parts is guaranteed.

Premium service contract



All servicing and maintenance at a fixed price: The Premium Service Contract guarantees you absolute certainty with regards to planning and expenses.

2G TrainingCenter

Practical knowledge. Directly from the manufacturer

As one of the leading manufacturers of combined heat and power systems with an internal research and development department, 2G Energy constantly works towards perfecting cogeneration system technology.

No matter if you are a customer, operator, or partner: you can benefit from the most recent technology development and practical experiences made directly by the manufacturer. We offer user-specific Sales and Service training for our complete product range, either at the 2G TrainingCenter in Heek (Germany), at one of our international locations or, upon request, directly at your location.

Many of the courses we offer are composed in-person and digital training. In these cases, the online training is required for in-person session. This process balances the theoretical knowledge among participants which leads to a deeper and more efficient in-person learning experience.



MY2G

Your central platform for intelligent asset management

MY2G is your central platform for intelligent asset management. It combines cutting-edge AI support and personalized service options to personalize your asset management. With MY2G, you have access to data, services, and tools from anywhere, anytime. Take the first step toward digitally optimized asset management for free.



About the platform:
my.2-g.ag



Plant monitoring

Access to operating states and performance data



Artificial intelligence

Fast answers and assistance from our AI-based virtual assistant I.R.I.S.



Documents ready to hand

Easy download of operating manuals, maintenance reports, software, and other relevant documents



Online service ordering

Exclusively in Germany: Request and track service calls directly via the platform



MY2G Store

The right solutions for your systems can be easily booked online.



Would you like to generate your own electricity and heat in the future and sustainably reduce your energy costs? Whether with highly efficient heat pumps or through the use of modern cogeneration systems – we offer you customized solutions for an economical and environmentally friendly energy supply.

Contact us – we would be happy to advise you!

**2G Energy AG | Benzstraße 3 | 48619 Heek |
T +49 (0) 2568 9347-0 | info@2-g.de | 2-g.com**